



POWER SUPPLY

- AC 100-240V Wide-range Input
- Width only 48mm
- Efficiency up to 95.6%
- Excellent Partial Load Efficiency
- 20% Output Power Reserves
- Easy Fuse Breaking – 3 times nominal current for 12ms
- Safe Hiccup^{PLUS} Overload Mode
- Active Power Factor Correction (PFC)
- Minimal Inrush Current Surge
- Full Power Between -25°C and +60°C
- DC-OK Relay Contact
- Current Sharing Feature for Parallel Use
- 3 Year Warranty

GENERAL DESCRIPTION

The Dimension CP-Series are cost optimized power supplies without compromising quality, reliability and performance. The most outstanding features of the CP20 series are the high efficiency, electronic inrush current limitation, active PFC, wide operational temperature range and the extraordinary small size.

The CP20.241-C1 is equipped with conformal coated pc-boards preferred for applications in harsh areas.

The CP20.241-S1 is equipped with quick-connect spring-clamp terminals preferred for applications which are exposed to mechanical vibration.

The CP20.241-S2 is equipped with push-in terminals optimized for automated cabinet wiring.

The devices have a power reserve of 20% included, which may even be used continuously at temperatures up to +45°C.

High immunity to transients and power surges as well as low electromagnetic emission, a DC-OK relay contact and a large international approval package for a variety of applications makes this unit suitable for nearly every situation.

SHORT-FORM DATA

Output voltage	DC 24V	Nominal
Adjustment range	24 - 28V	Factory set 24.1V
Output current	24.0 - 20.6A	Below +45°C ambient
	20.0 - 17.1A	At +60°C ambient
	15.0 - 13.0A	At +70°C ambient
Derate linearly between +45°C and +70°C		
Input voltage AC	AC 100-240V	-15%/+10%
Mains frequency	50-60Hz	±6%
Input current AC	4.26 / 2.23A	At 120 / 230Vac
Power factor	0.99 / 0.95	At 120 / 230Vac
Input voltage DC	DC 110-150V	±20%
Input current DC	4.64A	At 110Vdc
AC Inrush current	10.0 / 4.5A	At 120 / 230Vac
Efficiency	94.2 / 95.6%	At 120 / 230Vac
Losses	29.6 / 22.1W	At 120 / 230Vac
Hold-up time	32ms	
Temperature range	-25°C to +70°C	
Size (WxHxD)	48x124x127mm	Without DIN-rail
Weight	830g / 1.83lb	

ORDER NUMBERS

Power Supply	CP20.241	
	CP20.241-C1	With conformal coated pc-boards
	CP20.241-S1	With quick-connect spring-clamp terminals
	CP20.241-S2	With push-in terminals
Accessory	ZM5.WALL	Wall/Panel mount bracket
	UF20.241	Buffer module
	YR40.242	Redundancy module
	YR40.245	Redundancy module

MARKINGS



May 2017 / Rev. 0.3 DS-CP20.241-EN
All parameters are typical values specified at 24V, 20A output, 230Vac input, 25°C ambient and after a 5 minutes run-in time unless otherwise noted.

INDEX

	Page		Page
1. Intended Use	3	22. Physical Dimensions and Weight	19
2. Installation Requirements.....	3	23. Accessories	20
3. AC-Input.....	4	23.1. UF20.241 Buffer Module	20
4. DC-Input.....	5	23.2. YR40.242 - Redundancy Modules	20
5. Input Inrush Current	5	23.3. YR40.245 - Redundancy Modules	20
6. Output	6	23.4. ZM5.WALL – Wall/Panel Mount Bracket .	21
7. Hold-up Time.....	8	24. Application Notes.....	22
8. DC-OK Relay Contact	8	24.1. Peak Current Capability	22
9. Efficiency and Power Losses.....	9	24.2. Back-feeding Loads	23
10. Lifetime Expectancy	10	24.3. External Input Protection.....	23
11. MTBF	10	24.4. Output Circuit Breakers.....	23
12. Functional Diagram.....	11	24.5. Series Operation	24
13. Terminals and Wiring.....	11	24.6. Parallel Use to Increase Output Power....	24
14. Front Side and User Elements.....	13	24.7. Parallel Use for Redundancy	25
15. EMC.....	14	24.8. Inductive and Capacitive Loads.....	26
16. Environment.....	15	24.9. Charging of Batteries	26
17. Protection Features	16	24.10. Operation on Two Phases	26
18. Safety Features	16	24.11. Use in a Tightly Sealed Enclosure	26
19. Dielectric Strength	17	24.12. Mounting Orientations	27
20. Approvals.....	18		
21. RoHS, REACH and Other Fulfilled Standards ...	18		

The information given in this document is correct to the best of our knowledge and experience at the time of publication. If not expressly agreed otherwise, this information does not represent a warranty in the legal sense of the word. As the state of our knowledge and experience is constantly changing, the information in this data sheet is subject to revision. We therefore kindly ask you to always use the latest issue of this document (available under www.pulspower.com). No part of this document may be reproduced or utilized in any form without our prior permission in writing.

TERMINOLOGY AND ABBREVIATIONS

PE and \oplus symbol	PE is the abbreviation for Protective Earth and has the same meaning as the symbol \oplus .
Earth, Ground	This document uses the term "earth" which is the same as the U.S. term "ground".
T.b.d.	To be defined, value or description will follow later.
AC 230V	A figure displayed with the AC or DC before the value represents a nominal voltage with standard tolerances (usually $\pm 15\%$) included. E.g.: DC 12V describes a 12V battery disregarding whether it is full (13.7V) or flat (10V)
230Vac	A figure with the unit (Vac) at the end is a momentary figure without any additional tolerances included.
50Hz vs. 60Hz	As long as not otherwise stated, AC 230V parameters are valid at 50Hz mains frequency.
may	A key word indicating flexibility of choice with no implied preference.
shall	A key word indicating a mandatory requirement.
should	A key word indicating flexibility of choice with a strongly preferred implementation.

May 2017 / Rev. 0.3 DS-CP20.241-EN
All parameters are typical values specified at 24V, 20A output, 230Vac input, 25°C ambient and after a 5 minutes run-in time unless otherwise noted.

1. INTENDED USE

This device is designed for installation in an enclosure and is intended for the general professional use such as in industrial control, office, communication, and instrumentation equipment.

Do not use this power supply in equipment, where malfunction may cause severe personal injury or threaten human life.

2. INSTALLATION REQUIREMENTS

This device may only be installed and put into operation by qualified personnel.

This device does not contain serviceable parts. The tripping of an internal fuse is caused by an internal defect.

If damage or malfunction should occur during installation or operation, immediately turn power off and send unit to the factory for inspection.

Mount the unit on a DIN-rail so that the input terminals are located on the bottom of the unit. For other mounting orientations see de-rating requirements in this document. See chapter 24.12.

This device is designed for convection cooling and does not require an external fan. Do not obstruct airflow and do not cover ventilation grid (e.g. cable conduits) by more than 15%!

Keep the following installation clearances: 40mm on top, 20mm on the bottom, 5mm on the left and right sides are recommended when the device is loaded permanently with more than 50% of the rated power. Increase this clearance to 15mm in case the adjacent device is a heat source (e.g. another power supply).

A disconnecting means shall be provided for the output of the power supplies when used in applications according to CSA C22.2 No 107.1-01.

⚠ WARNING Risk of electrical shock, fire, personal injury or death.

- Do not use the power supply without proper grounding (Protective Earth). Use the terminal on the input block for earth connection and not one of the screws on the housing.
- Turn power off before working on the device. Protect against inadvertent re-powering.
- Make sure that the wiring is correct by following all local and national codes.
- Do not modify or repair the unit.
- Do not open the unit as high voltages are present inside.
- Use caution to prevent any foreign objects from entering the housing.
- Do not use in wet locations or in areas where moisture or condensation can be expected.
- Do not touch during power-on, and immediately after power-off. Hot surfaces may cause burns.

3. AC-INPUT

AC input	nom.	AC 100-240V	Suitable for TN-, TT- and IT mains networks
AC input range	min.	85-264Vac	Continuous operation
	min.	264-300Vac	< 500ms
Allowed voltage L or N to earth	max.	300Vac	Continuous, IEC 62103
Input frequency	nom.	50–60Hz	±6%
Turn-on voltage	typ.	82Vac	Steady-state value, see Fig. 3-1
Shut-down voltage	typ.	72Vac	Steady-state value, see Fig. 3-1
External input protection	See recommendations in chapter 24.3.		

		AC 100V	AC 120V	AC 230V	
Input current	typ.	5.15A	4.26A	2.23A	At 24V, 20A, see Fig. 3-3
Power factor*)	typ.	0.996	0.996	0.980	At 24V, 20A, see Fig. 3-4
Crest factor**)	typ.	1.65	1.63	1.63	At 24V, 20A
Start-up delay	typ.	450ms	420ms	440ms	See Fig. 3-2
Rise time	typ.	45ms	45ms	45ms	At 24V, 20A const. current load, 0mF load capacitance, see Fig. 3-2
	typ.	90ms	90ms	90ms	At 24V, 20A const. current load, 20mF load capacitance,, see Fig. 3-2
Turn-on overshoot	max.	200mV	200mV	200mV	See Fig. 3-2

*) The power factor is the ratio of the true (or real) power to the apparent power in an AC circuit.

**) The crest factor is the mathematical ratio of the peak value to RMS value of the input current waveform.

Fig. 3-1 **Input voltage range**

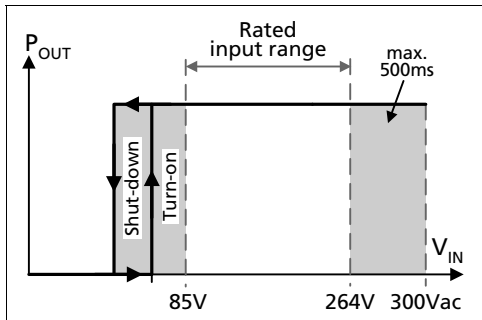

Fig. 3-3 **Input current vs. output current at 24V output voltage**

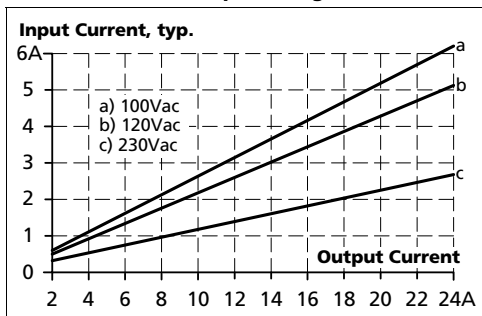

Fig. 3-2 **Turn-on behavior, definitions**

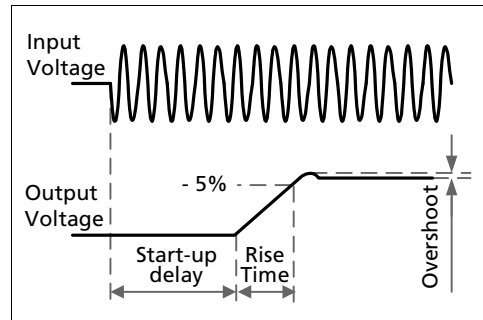
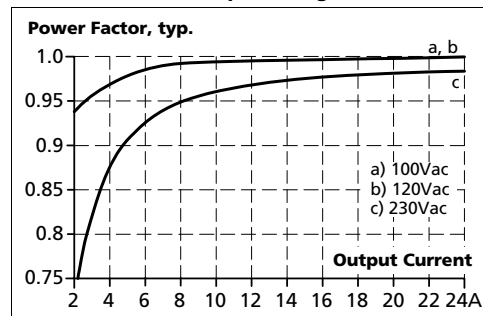

Fig. 3-4 **Power factor vs. output current at 24V output voltage**



4. DC-INPUT

DC input	nom.	DC 110-150V	±20%
DC input range	min.	88-187Vdc	Continuous operation
DC input current	typ.	4.64A	At 110Vdc, at 24V, 20A
Allowed Voltage L/N to Earth	max.	375Vdc	Continuous, IEC 62477-1
Turn-on voltage	typ.	80Vdc	Steady state value
Shut-down voltage	typ.	70Vdc	Steady state value

Fig. 4-1 **Wiring for DC Input**

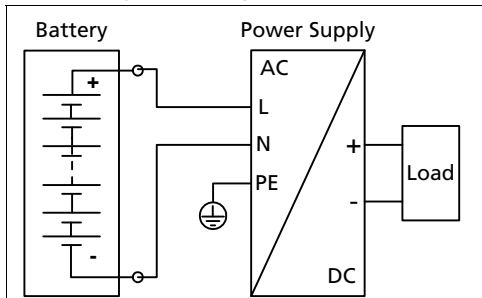

Instructions for DC use:

- Use a battery or a similar DC source. A supply from the intermediate DC-bus of a frequency converter is not recommended and can cause a malfunction or damage the unit.
- Connect +pole to L and -pole to N.
- Connect the PE terminal to an earth wire or to the machine ground.

5. INPUT INRUSH CURRENT

An active inrush limitation circuit limits the input inrush current after turn-on of the input voltage. The charging current into EMI suppression capacitors is disregarded in the first microseconds after switch-on.

		AC 100V	AC 120V	AC 230V	
Inrush current	max.	15A _{peak}	12A _{peak}	5.5A _{peak}	Temperature independent
	typ.	12A _{peak}	10A _{peak}	4.5A _{peak}	Temperature independent
Inrush energy	max.	negligible small			Temperature independent
Inrush delay	typ.	500ms	450ms	450ms	Start-up delay plus rise time

Fig. 5-1 **Typical input inrush current behaviour at nominal load and 25°C ambient**

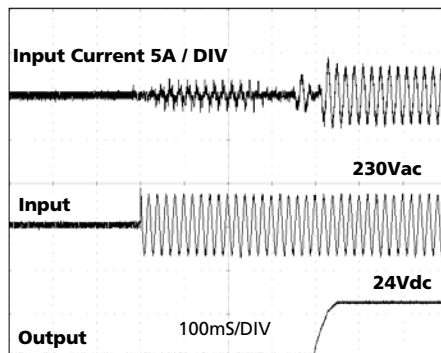

May 2017 / Rev. 0.3 DS-CP20.241-EN
All parameters are typical values specified at 24V, 20A output, 230Vac input, 25°C ambient and after a 5 minutes run-in time unless otherwise noted.

6. OUTPUT

Output voltage	nom.	24V	
Adjustment range	min.	24-28V	Guaranteed
	max.	30V ⁴⁾	At clockwise end position of potentiometer
Factory settings	typ.	24.1V	±0.2%, at full load, cold unit, in "single use" mode
	typ.	24.1V	±0.2%, at full load, cold unit, in "parallel use" mode
	typ.	25.1V	At no load, cold unit, in "parallel use" mode
Line regulation	max.	10mV	At 85-300Vac input voltage change
Load regulation	max.	100mV	In "single use" mode: static value, 0A → 20A, see Fig. 6-1
	typ.	1000mV	In "parallel use" mode: static value, 0A → 20A, see Fig. 6-2
Ripple and noise voltage	max.	50mVpp	20Hz to 20MHz, 50Ohm
Output current	nom.	20A	At 24V, ambient temperature <60°C, see Fig. 6-1
	nom.	24A ¹⁾	At 24V, ambient temperature <45°C, see Fig. 6-1
	nom.	17.1A	At 28V, ambient temperature <60°C, see Fig. 6-1
	nom.	20.6A ¹⁾	At 28V, ambient temperature <45°C, see Fig. 6-1
	typ.	60A	Up to 12ms, output voltage stays above 20V, see Fig. 6-4, This peak current is available once every five seconds. See chapter 24.1 for more peak current measurements.
Output power	nom.	480W	Continuously available
	nom.	576W ¹⁾	Power Boost ¹⁾
Overload behaviour		cont. current	Output voltage > 13Vdc, see Fig. 6-1
		Hiccup ^{PLUS} mode ²⁾	Output voltage < 13Vdc, see Fig. 6-1
Short-circuit current	min.	26A ³⁾	Load impedance <10mOhm, see Fig. 6-3
	max.	31A ³⁾	Load impedance <10mOhm, see Fig. 6-3
	max.	9.8A ³⁾	Average (R.M.S.) current, load impedance 50mOhm, see Fig. 6-3
	min.	55A	Up to 12ms, load impedance <10mOhm, see Fig. 6-4
	typ.	70A	Up to 12ms, load impedance <10mOhm, see Fig. 6-4
Output capacitance	typ.	8 500µF	Included inside the power supply

- 1) **Power Boost**
This power/ current is continuously allowed up to an ambient temperature of 45°C. Above 45°C, do not use this power/ current longer than a duty cycle of 10% and/ or not longer than 1 minute every 10 minutes.
- 2) **Hiccup^{PLUS} Mode**
At heavy overloads (when output voltage falls below 13V), the power supply delivers continuous output current for 2s. After this, the output is switched off for approx. 18s before a new start attempt is automatically performed. This cycle is repeated as long as the overload exists. If the overload has been cleared, the device will operate normally. See Fig. 6-3.
- 3) Discharge current of output capacitors is not included.
- 4) This is the maximum output voltage which can occur at the clockwise end position of the potentiometer due to tolerances. It is not guaranteed value which can be achieved. The typical value is about 28.5V (in "single use" mode).

Fig. 6-1 Output voltage vs. output current, typ.

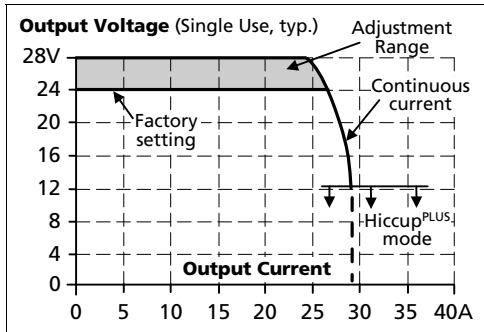

Fig. 6-2 Output voltage in "parallel use" mode, typ.

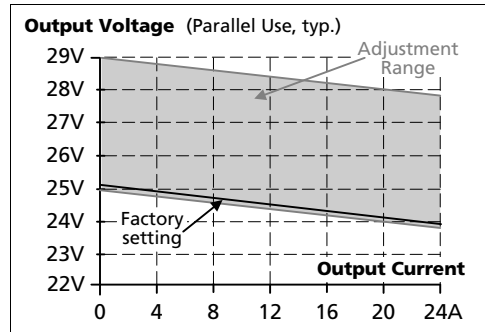

Fig. 6-3 Short-circuit on output, Hiccup^{PLUS} mode, typ.

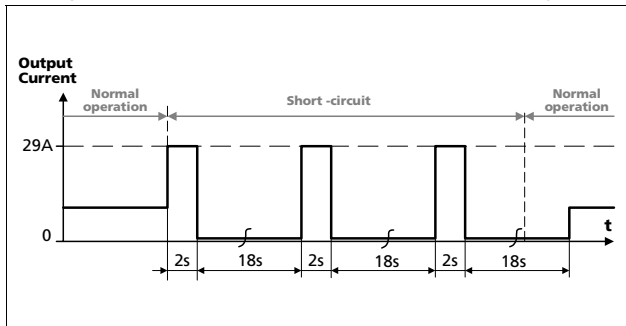
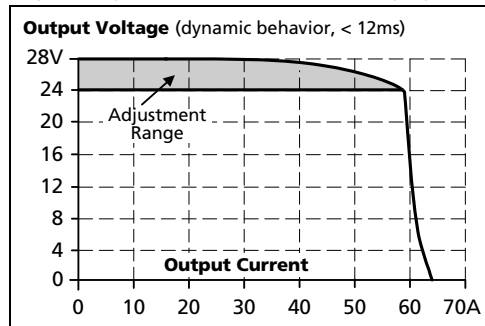

Fig. 6-4 Dynamic overcurrent capability, typ.



May 2017 / Rev. 0.3 DS-CP20.241-EN
All parameters are typical values specified at 24V, 20A output, 230Vac input, 25°C ambient and after a 5 minutes run-in time unless otherwise noted.

7. HOLD-UP TIME

		AC 100V	AC 120V	AC 230V	
Hold-up Time	typ.	65ms	65ms	65ms	At 24V, 10A, see Fig. 7-1
	min.	54ms	54ms	54ms	At 24V, 10A, see Fig. 7-1
	typ.	32ms	32ms	32ms	At 24V, 20A, see Fig. 7-1
	min.	24ms	24ms	24ms	At 24V, 20A, see Fig. 7-1

Fig. 7-1 **Hold-up time vs. input voltage**

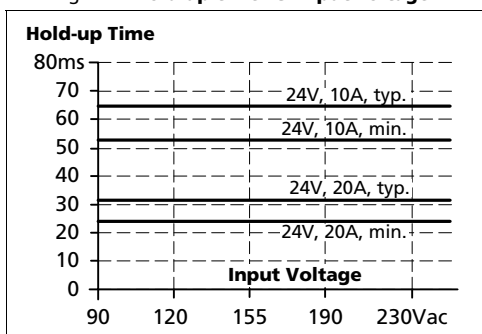
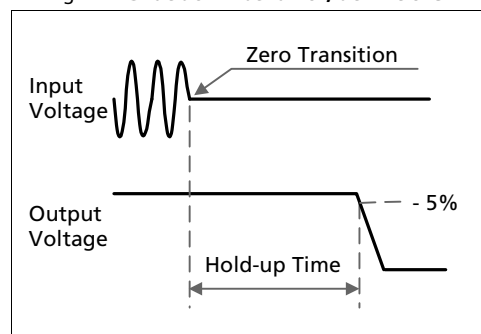

Fig. 7-2 **Shut-down behavior, definitions**



8. DC-OK RELAY CONTACT

The DC-OK relay contact reports an output voltage above 90% of the adjusted output voltage of a running device.

Contact closes	As soon as the output voltage reaches typ. 90% of the adjusted output voltage level.
Contact opens	As soon as the output voltage dips more than 10% below the adjusted output voltage. Short dips will be extended to a signal length of 100ms. Dips shorter than 1ms will be ignored.
Contact ratings	Maximal 60Vdc 0.3A, 30Vdc 1A, 30Vac 0.5A, resistive load Minimal permissible load: 1mA at 5Vdc
Isolation voltage	See dielectric strength table in section 18.

Fig. 8-1 **DC-ok relay contact behavior**

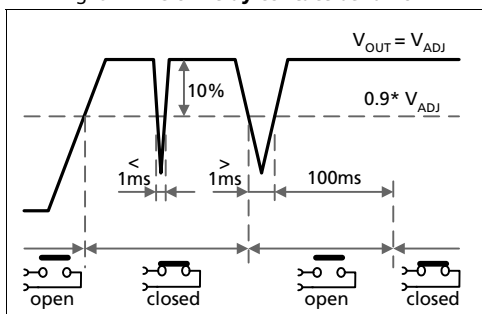

May 2017 / Rev. 0.3 DS-CP20.241-EN
All parameters are typical values specified at 24V, 20A output, 230Vac input, 25°C ambient and after a 5 minutes run-in time unless otherwise noted.

9. EFFICIENCY AND POWER LOSSES

		AC 100V	AC 120V	AC 230V	
Efficiency	typ.	93.6%	94.2%	95.6%	At 24V, 20A
	typ.	93.5%	94.1%	95.5%	At 24V, 24A (Power Boost)
Average efficiency*)	typ.	93.2%	93.8%	95.0%	25% at 5A, 25% at 10A, 25% at 15A, 25% at 20A
Power losses	typ.	2.5W	2.2W	2.2W	At 24V, 0A
	typ.	16.0W	15.0W	12.5W	At 24V, 10A
	typ.	32.8W	29.6W	22.1W	At 24V, 20A
	typ.	40.0W	36.1W	27.1W	At 24V, 24A (Power Boost)

*) The average efficiency is an assumption for a typical application where the power supply is loaded with 25% of the nominal load for 25% of the time, 50% of the nominal load for another 25% of the time, 75% of the nominal load for another 25% of the time and with 100% of the nominal load for the rest of the time.

Fig. 9-1 Efficiency vs. output current at 24V, typ

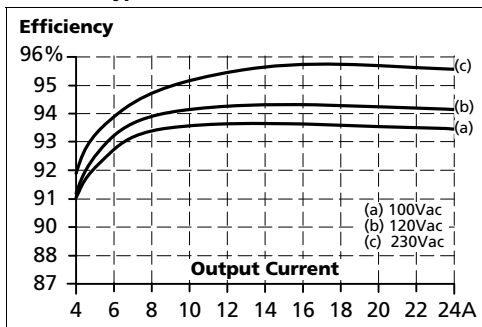

Fig. 9-2 Losses vs. output current at 24V, typ.

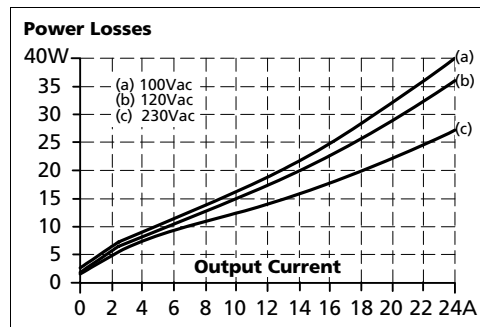

Fig. 9-3 Efficiency vs. input voltage at 24V, 20A, typ.

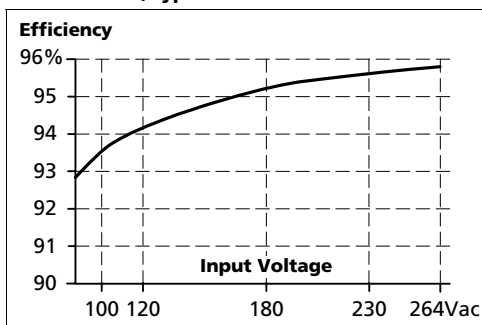
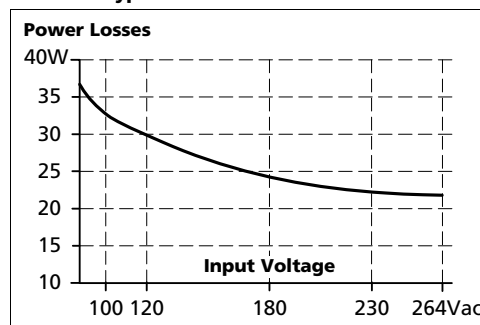

Fig. 9-4 Losses vs. input voltage at 24V, 20A, typ.



10. LIFETIME EXPECTANCY

The Lifetime expectancy shown in the table indicates the minimum operating hours (service life) and is determined by the lifetime expectancy of the built-in electrolytic capacitors. Lifetime expectancy is specified in operational hours and is calculated according to the capacitor's manufacturer specification. The manufacturer of the electrolytic capacitors only guarantees a maximum life of up to 15 years (131 400h). Any number exceeding this value is a calculated theoretical lifetime which can be used to compare devices.

	AC 100V	AC 120V	AC 230V	
Lifetime expectancy	123 000h	149 000h	173 000h	At 24V, 10A and 40°C
	348 000h	422 000h	488 000h	At 24V, 10A and 25°C
	48 000h	60 000h	94 000h	At 24V, 20A and 40°C
	136 000h	169 000h	265 000h	At 24V, 20A and 25°C
	23 000h	31 000h	54 000h	At 24V, 24A and 40°C
	64 000h	88 000h	152 000h	At 24V, 24A and 25°C

11. MTBF

MTBF stands for **Mean Time Between Failure**, which is calculated according to statistical device failures, and indicates reliability of a device. It is the statistical representation of the likelihood of a unit to fail and does not necessarily represent the life of a product.

The MTBF figure is a statistical representation of the likelihood of a device to fail. A MTBF figure of e.g. 1 000 000h means that statistically one unit will fail every 100 hours if 10 000 units are installed in the field. However, it can not be determined if the failed unit has been running for 50 000h or only for 100h.

For these types of units the MTTF (**Mean Time To Failure**) value is the same value as the MTBF value.

	AC 100V	AC 120V	AC 230V	
MTBF SN 29500, IEC 61709	422 000h	445 000h	590 000h	At 24V, 20A and 40°C
	790 000h	832 000h	1 060 000h	At 24V, 20A and 25°C
MTBF MIL HDBK 217F	186 000h	191 000h	226 000h	At 24V, 20A and 40°C; Ground Benign GB40
	256 000h	263 000h	313 000h	At 24V, 20A and 25°C; Ground Benign GB25
	40 000h	42 000h	50 000h	At 24V, 20A and 40°C; Ground Fixed GF40
	53 000h	55 000h	67 000h	At 24V, 20A and 25°C; Ground Fixed GF25

12. FUNCTIONAL DIAGRAM

Fig. 12-1 **Functional diagram CP20.241, CP20.241-C1, CP20.241-S1**

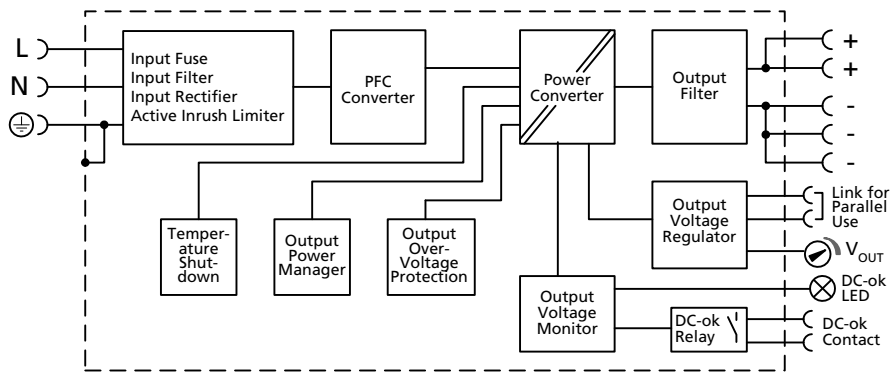
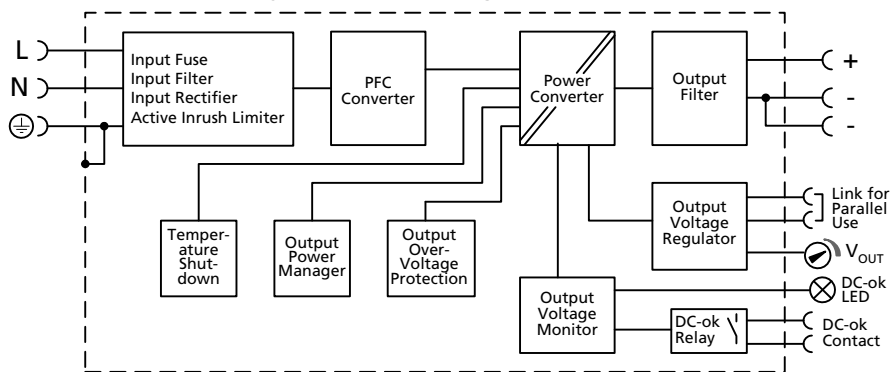

Fig. 12-2 **Functional diagram CP20,241-S2**



13. TERMINALS AND WIRING

The terminals are IP20 Finger safe constructed and suitable for field- and factory wiring.

CP20.241, CP20.241-C1	Input	Output	DC-OK-Signal
Type	Screw termination	Screw termination	Push-in termination
Solid wire	Max. 6mm ²	Max. 6mm ²	Max. 1.5mm ²
Stranded wire	Max. 4mm ²	Max. 4mm ²	Max. 1.5mm ²
American Wire Gauge	AWG 20-10	AWG 20-10	AWG 24-16
Max. wire diameter (including ferrules)	2.8mm	2.8mm	1.6mm
Recommended tightening torque	Max. 1Nm, 9lb-in	Max. 1Nm, 9lb-in	-
Wire stripping length	7mm / 0.28inch	7mm / 0.28inch	7mm / 0.28inch
Screwdriver	3.5mm slotted or cross-head No 2	3.5mm slotted or cross-head No 2	3mm slotted to open the spring

May 2017 / Rev. 0.3 DS-CP20.241-EN
All parameters are typical values specified at 24V, 20A output, 230Vac input, 25°C ambient and after a 5 minutes run-in time unless otherwise noted.

CP20.241-S1

	Input	Output	DC-OK-Signal
Type	Quick-connect spring-clamp termination	Quick-connect spring-clamp termination	Push-in termination
Solid wire	Max. 6mm ²	Max. 6mm ²	Max. 1.5mm ²
Stranded wire	Max. 4mm ²	Max. 4mm ²	Max. 1.5mm ²
American Wire Gauge	AWG 20-10	AWG 20-10	AWG 24-16
Max. wire diameter (including ferrules)	2.8mm	2.8mm	1.6mm
Wire stripping length	10mm / 0.4inch	10mm / 0.4inch	7mm / 0.28inch
Screwdriver	-	-	3mm slotted to open the spring

CP20.241-S2

	Input	Output	DC-OK-Signal
Type	Push-in termination	Push-in termination	Push-in termination
Solid wire	Max. 2.5mm ²	Max. 10mm ²	Max. 1.5mm ²
Stranded wire	Max. 2.5mm ²	Max. 6mm ²	Max. 1.5mm ²
Stranded wire with ferrules	Max. 1.5mm ²	Max. 4mm ²	Max. 1.5mm ²
American Wire Gauge	AWG 24-12	AWG 24-8	AWG 24-16
Max. wire diameter (including ferrules)	2.3mm	3.3mm	1.6mm
Wire stripping length	10mm / 0.4inch	15mm / 0.6inch	7mm / 0.28inch
Screwdriver	3.0mm slotted to open the spring	3.5mm slotted to open the spring	3mm slotted to open the spring

Instructions for wiring:

- Use appropriate copper cables that are designed for minimum operating temperatures of:
 - 60°C for ambient up to 45°C and
 - 75°C for ambient up to 60°C and
 - 90°C for ambient up to 70°C minimum.
- Follow national installation codes and installation regulations!
- Ensure that all strands of a stranded wire enter the terminal connection!
- Unused terminal compartments should be securely tightened.
- Ferrules are allowed.

T

Daisy chaining:

Daisy chaining (jumping from one power supply output to the next) is allowed as long as the average output current through one terminal pin does not exceed 25A. If the current is higher, use a separate distribution terminal block as shown in Fig. 13-2.

Fig. 13-1 Daisy chaining of outputs

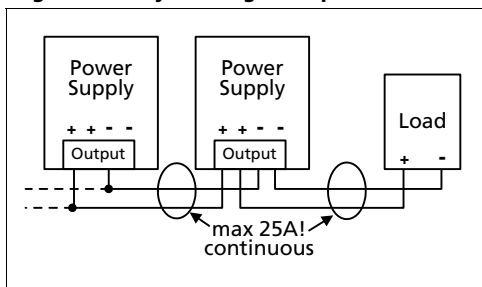
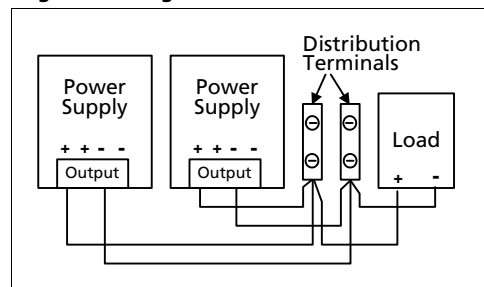

Fig. 13-2 Using distribution terminals



14. FRONT SIDE AND USER ELEMENTS

Fig. 14-1 Front side

CP20.241, CP20.241-C1

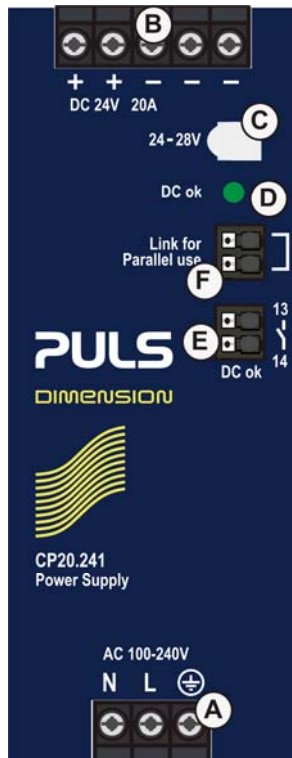

CP20.241-S1

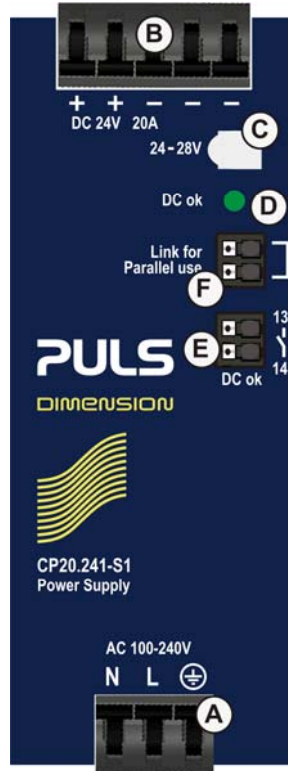

CP20.241-S2

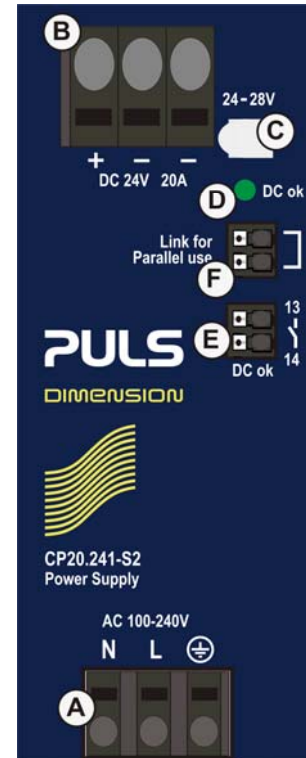

A Input Terminals

N, L Line input

PE (Protective Earth) input

B Output Terminals

CP20.241-S2: one + pole and two identical - poles

All other units: two identical + poles and three identical - poles

+ Positive output

- Negative (return) output

C Output Voltage Potentiometer

Open the flap to adjust the output voltage.

D DC-OK LED (green)

On, when the output voltage is >90% of the adjusted output voltage

E DC-OK Relay Contact

The DC-OK relay contact is synchronized with the DC-OK LED. See chapter 8 for details.

F "Parallel Use" "Single Use" Link

Link the two terminal poles when power supplies are connected in parallel. In order to achieve a sharing of the load current between the individual power supplies, the "parallel use" regulates the output voltage in such a manner that the voltage at no load is approx. 4% higher than at nominal load. See also chapter 24.6.

15. EMC

The power supply is suitable for applications in industrial environment as well as in residential, commercial and light industry environment without any restrictions.

EMC Immunity		According generic standards: EN 61000-6-1 and EN 61000-6-2		
Electrostatic discharge	EN 61000-4-2	contact discharge air discharge	8kV 15kV	Criterion A Criterion A
Electromagnetic RF field	EN 61000-4-3	80MHz-2.7GHz	20V/m	Criterion A
Fast transients (Burst)	EN 61000-4-4	input lines	4kV	Criterion A
		output lines	2kV	Criterion A
		DC-OK signal (coupling clamp)	2kV	Criterion A
Surge voltage on input	EN 61000-4-5	L → N	2kV	Criterion A
		L → PE, N → PE	4kV	Criterion A
Surge voltage on output	EN 61000-4-5	+ → -	1kV	Criterion A
		+ / - → PE	2kV	Criterion A
Surge voltage on DC-OK	EN 61000-4-5	DC-OK signal → PE	1kV	Criterion A
Conducted disturbance	EN 61000-4-6	0.15-80MHz	20V	Criterion A
Mains voltage dips	EN 61000-4-11	0% of 100Vac	0Vac, 20ms	Criterion A
		40% of 100Vac	40Vac, 200ms	Criterion C
		70% of 100Vac	70Vac, 500ms	Criterion A
		0% of 200Vac	0Vac, 20ms	Criterion A
		40% of 200Vac	80Vac, 200ms	Criterion A
70% of 200Vac	140Vac, 500ms	Criterion A		
Voltage interruptions	EN 61000-4-11	0% of 200Vac (=0V)	5000ms	Criterion C
Voltage sags	SEMI F47 0706	dips on the input voltage according to SEMI F47 standard		
		80% of 120Vac (96Vac)	1000ms	Criterion A
		70% of 120Vac (84Vac)	500ms	Criterion A
		50% of 120Vac (60Vac)	200ms	Criterion A
Powerful transients	VDE 0160	over entire load range	750V, 0.3ms	Criterion A

Criteria:
A: Power supply shows normal operation behavior within the defined limits.
C: Temporary loss of function is possible. Power supply may shut-down and restarts by itself. No damage or hazards for the power supply will occur.

EMC Emission		According generic standards: EN 61000-6-3 and EN 61000-6-4		
Conducted emission input lines	EN 55011, EN 55022, FCC Part 15, CISPR 11, CISPR 22	Class B		
Conducted emission output lines**)	IEC/CISPR 16-1-2, IEC/CISPR 16-2-1	T.B.D		
Radiated emission	EN 55011, EN 55022	Class B		
Harmonic input current	EN 61000-3-2	Class A equipment: fulfilled Class C equipment: fulfilled in the load range from 8 to 24A		
Voltage fluctuations, flicker	EN 61000-3-3	Fulfilled*)		

This device complies with FCC Part 15 rules.
 Operation is subjected to following two conditions: (1) this device may not cause harmful interference, and (2) this device must accept any interference received, including interference that may cause undesired operation.

*) tested with constant current loads, non pulsing
 **) for information only, not mandatory for EN 61000-6-3

Switching Frequencies	The power supply has two converters with two different switching frequencies included.	
Switching frequency 1	70kHz to 130kHz	PFC converter, input voltage and output power dependent
Switching frequency 2	80kHz to 140kHz	Main converter, output power dependent

16. ENVIRONMENT

Operational temperature ¹⁾	-25°C to +70°C (-13°F to 158°F)	Reduce output power according Fig. 15-1
Storage temperature	-40°C to +85°C (-40°F to 185°F)	For storage and transportation
Output de-rating	6.4W/°C 12W/°C	45°C to 60°C (113°F to 140°F) 60°C to 70°C (140°F to 158°F)
Humidity ²⁾	5 to 95% r.h.	IEC 60068-2-30
Vibration sinusoidal	2-17.8Hz: ±1.6mm; 17.8-500Hz: 2g ³⁾ 2 hours / axis	IEC 60068-2-6
Shock	30g 6ms, 20g 11ms ³⁾ 3 bumps / direction, 18 bumps in total	IEC 60068-2-27
Altitude	0 to 2000m (0 to 6 560ft) 2000 to 6000m (6 560 to 20 000ft)	Without any restrictions Reduce output power or ambient temperature, see Fig. 15-2 Overvoltage category II according to IEC 62477-1,
Altitude de-rating	30W/1000m or 5°C/1000m	> 2000m (6500ft), see Fig. 15-2
Over-voltage category	III II	IEC 62477-1, altitudes up to 2000m For altitudes from 2000m to 6000m
Degree of pollution	2	IEC 62477-1, not conductive
LABS compatibility	The unit does not release any silicone or other LABS-critical substances and is suitable for use in paint shops.	
Audible noise	Some small audible noise will be emitted from the power supply	
Corrosive gases	ISA-71.04-1985, Severity Level G3, IEC 60068-2-60 Test Ke Method 4	

- 1) Operational temperature is the same as the ambient or surrounding temperature and is defined as the air temperature 2cm below the unit.
- 2) Do not energize while condensation is present
- 3) Tested in combination with DIN-Rails according to EN 60715 with a height of 15mm and a thickness of 1.3mm and standard orientation.

Fig. 16-1 Output current vs. ambient temp.

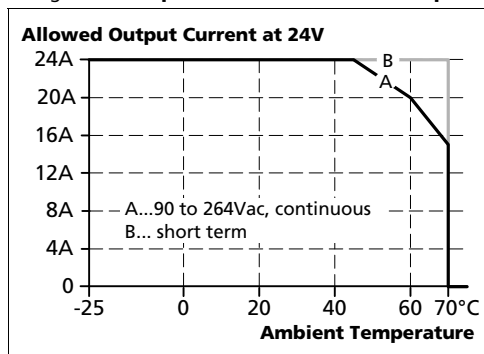
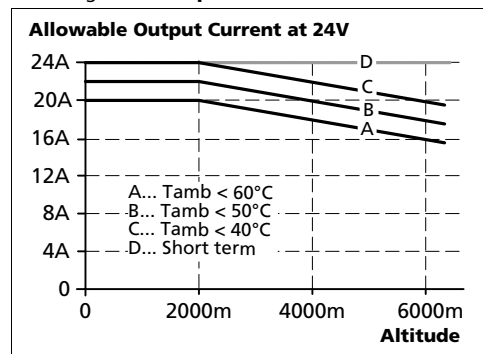

Fig. 16-2 Output current vs. altitude



17. PROTECTION FEATURES

Output protection	Electronically protected against overload, no-load and short-circuits*)	
Output over-voltage protection	typ. 30.5Vdc max. 32Vdc	In case of an internal power supply defect, a redundant circuit limits the maximum output voltage. The output shuts down and automatically attempts to restart.
Degree of protection	IP 20	EN/IEC 60529 Caution: For use in a controlled environment according to CSA 22.2 No 107.1-01.
Penetration protection	> 5mm	E.g. screws, small parts
Over-temperature protection	yes	Output shut-down with automatic restart
Input transient protection	MOV (Metal Oxide Varistor)	
Internal input fuse	included	Not user replaceable slow-blow high-braking capacity fuse

*) In case of a protection event, audible noise may occur.

18. SAFETY FEATURES

Input / output separation*)	SELV PELV double or reinforced insulation	IEC/EN 60950-1 IEC/EN 60204-1, EN 62477-1, IEC 60364-4-41
Class of protection	I	PE (Protective Earth) connection required
Isolation resistance	> 500MOhm	At delivered condition between input and output, measured with 500Vdc
	> 500MOhm	At delivered condition between input and PE, measured with 500Vdc
	> 500MOhm	At delivered condition between output and PE, measured with 500Vdc
	> 500MOhm	At delivered condition between output and DC-OK contacts, measured with 500Vdc
PE resistance	< 0.1Ohm	Resistance between PE terminal and the housing in the area of the DIN-rail mounting bracket.
Touch current (leakage current)	typ. 0.12mA / 0.31mA	100Vac, 50Hz, TN-,TT-mains / IT-mains
	typ. 0.18mA / 0.45mA	120Vac, 60Hz, TN-,TT-mains / IT-mains
	typ. 0.30mA / 0.76mA	230Vac, 50Hz, TN-,TT-mains / IT-mains
	max. 0.16mA / 0.38mA	110Vac, 50Hz, TN-,TT-mains / IT-mains
	max. 0.23mA / 0.55mA	132Vac, 60Hz, TN-,TT-mains / IT-mains
	max. 0.39mA / 0.94mA	264Vac, 50Hz, TN-,TT-mains / IT-mains

*) double or reinforced insulation

19. DIELECTRIC STRENGTH

The output voltage is floating and has no ohmic connection to the ground. Type and factory tests are conducted by the manufacturer. Field tests may be conducted in the field using the appropriate test equipment which applies the voltage with a slow ramp (2s up and 2s down). Connect all input-terminals together as well as all output poles before conducting the test. When testing, set the cut-off current settings to the value in the table below.

Fig. 19-1 Dielectric strength

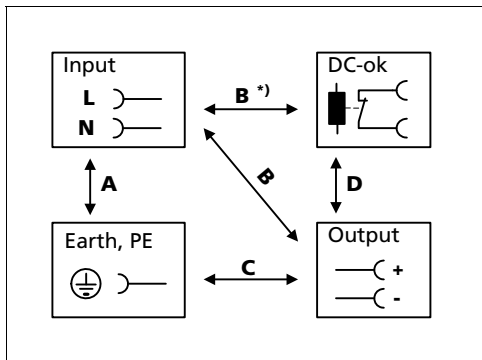









		A	B	C	D
Type test	60s	2500Vac	3000Vac	1000Vac	500Vac
Factory test	5s	2500Vac	2500Vac	500Vac	500Vac
Field test	5s	2000Vac	2000Vac	500Vac	500Vac
Cut-off current setting		> 10mA	> 10mA	> 20mA	> 1mA



To fulfil the PELV requirements according to EN60204-1 § 6.4.1, we recommend that either the + pole, the - pole or any other part of the output circuit shall be connected to the protective earth system. This helps to avoid situations in which a load starts unexpectedly or can not be switched off when unnoticed earth faults occur.

B*) When testing input to DC-OK ensure that the max. voltage between DC-OK and the output is not exceeded (column D). We recommend connecting DC-OK pins and the output pins together when performing the test.

20. APPROVALS

EC Declaration of Conformity		The CE mark indicates conformance with the - EMC directive, - Low-voltage directive and the - ATEX directive planned
IEC 60950-1 2 nd Edition planned		CB Scheme, Information Technology Equipment
UL 508 planned		Listed for use as Industrial Control Equipment; U.S.A. (UL 508) and Canada (C22.2 No. 107-1-01); E-File: E198865
UL 60950-1 2 nd Edition planned		Recognized for use as Information Technology Equipment, Level 5; U.S.A. (UL 60950-1) and Canada (C22.2 No. 60950-1); E-File: E137006 Applicable for altitudes up to 2000m.
ANSI / ISA 12.12.01-2007 Class I Div 2 planned		Recognized for use in Hazardous Location Class I Div 2 TX Groups A,B,C,D systems; U.S.A. (ANSI / ISA 12.12.01-2007) and Canada (C22.2 No. 213-M1987)
EN 60079-0, EN 60079-7 ATEX planned	 II 3G Ex eC nC II TX Gc	Approval for use in hazardous locations Zone 2 Category 3G. Number of ATEX certificate: T.B.D. The power supply must be built-in in an IP54 enclosure.
IEC 60079-0, IEC 60079-7 planned		Suitable for use in Class 1 Zone 2 Groups IIa, IIb and IIc locations. Number of IECEx certificate: T.B.D.
Marine planned		GL (Germanischer Lloyd) classified Environmental category: C, EMC2 Marine and offshore applications
EAC TR Registration planned		Registration for the Eurasian Customs Union market (Russia, Kazakhstan, Belarus)

21. ROHS, REACH AND OTHER FULFILLED STANDARDS

RoHS Directive		Directive 2011/65/EU of the European Parliament and the Council of June 8 th , 2011 on the restriction of the use of certain hazardous substances in electrical and electronic equipment.
REACH Directive		Directive 1907/2006/EU of the European Parliament and the Council of June 1 st , 2007 regarding the Registration, Evaluation, Authorisation and Restriction of Chemicals (REACH)

22. PHYSICAL DIMENSIONS AND WEIGHT

Width	48mm 1.89"
Height	124mm 4.88"
Depth	127mm 5.0" The DIN-rail height must be added to the unit depth to calculate the total required installation depth.
Weight	830g / 1.83lb
DIN-Rail	Use 35mm DIN-rails according to EN 60715 or EN 50022 with a height of 7.5 or 15mm.
Housing material	Body: Aluminium alloy Cover: zinc-plated steel
Installation clearances	See chapter 2

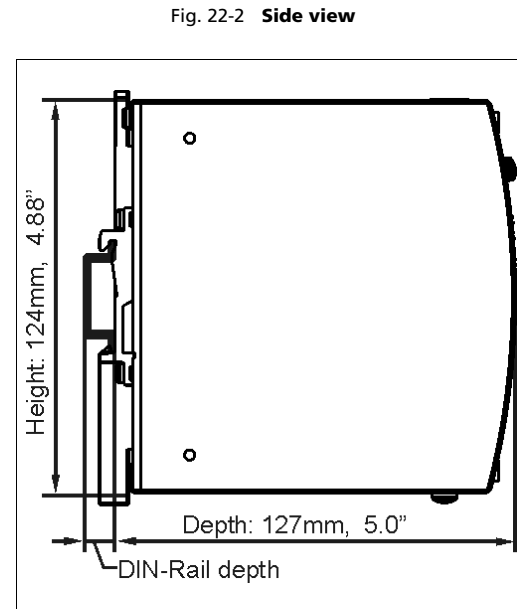
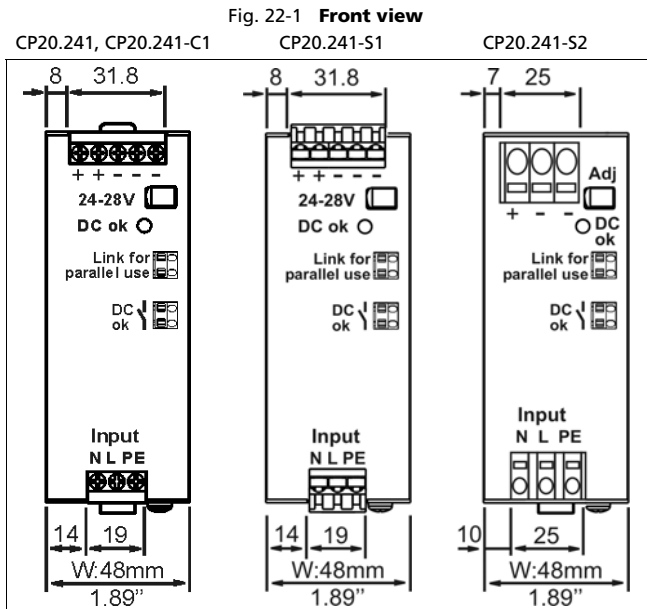

May 2017 / Rev. 0.3 DS-CP20.241-EN
All parameters are typical values specified at 24V, 20A output, 230Vac input, 25°C ambient and after a 5 minutes run-in time unless otherwise noted.

23. ACCESSORIES

23.1. UF20.241 BUFFER MODULE



This buffer unit is a supplementary device for DC 24V power supplies. It delivers power to bridge typical mains failures or extends the hold-up time after turn-off of the AC power. In times when the power supply provides sufficient voltages, the buffer unit stores energy in integrated electrolytic capacitors. In case of mains voltage fault, this energy is released again in a regulated process. One buffer module can deliver 20A additional current.

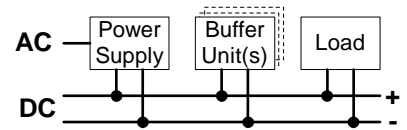

The buffer unit does not require any control wiring. It can be added in parallel to the load circuit at any given point. Buffer units can be added in parallel to increase the output ampacity or the hold-up time.

23.2. YR40.242 - REDUNDANCY MODULES



The YR40.242 redundancy module is equipped with two input channels (each 20A), which are individually decoupled by utilizing MOSFET technology. The output current can be as high as 40A. Using MOSFETs instead of diodes reduces the heat generation and the voltage drop between input and output. The YR40.242 does not require an additional auxiliary voltage and is self-powered even in case of a short circuit across the output.

Due to the low power losses, the unit is very slender and only requires 36mm width on the DIN-rail.

Further information and wiring configurations can be found in chapter 24.7.

23.3. YR40.245 - REDUNDANCY MODULES



The YR40.245 is a 40A single channel redundancy module, which is equipped with a plug connector on the output. The plug connector allows replacing the power supply or the redundancy module while the system is running. The plug connector avoids that the output wires can touch and short the load circuit.

The YR40.245 is very slender and only requires 46mm width on the DIN-rail. It also utilizes MOSFET technology instead of diodes for low heat generation and a minimal voltage drop between input and output. It does not require an additional auxiliary voltage and is self-powered even in case of a short circuit across the output.

Further information and wiring configurations can be found in chapter 24.7.

23.4. ZM5.WALL – WALL/PANEL MOUNT BRACKET

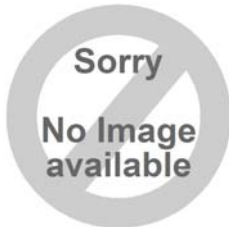

This bracket is used to mount the devices on a wall/panel without utilizing a DIN-Rail. It is suitable for CP20.241, CP20.241-C1, CP20.241-S1 and CP20.241-S2.

The bracket can be mounted without detaching the DIN-rail brackets.

Fig. 23-1 **Isometric view**
(Picture shows the CP20.241)

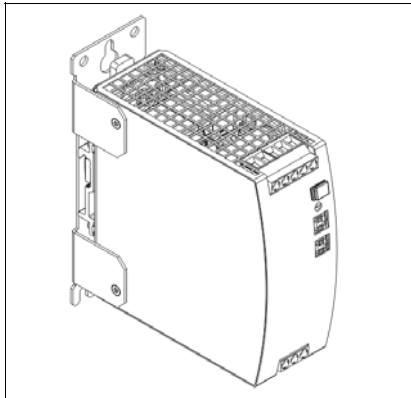

Fig. 23-2 **Isometric view-**
(Picture shows the CP20.241)

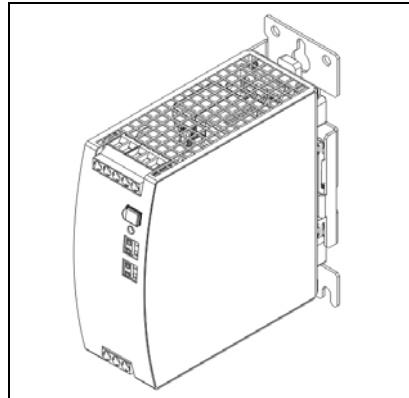

Fig. 23-3 **Isometric view**
(Picture shows the CP20.241)

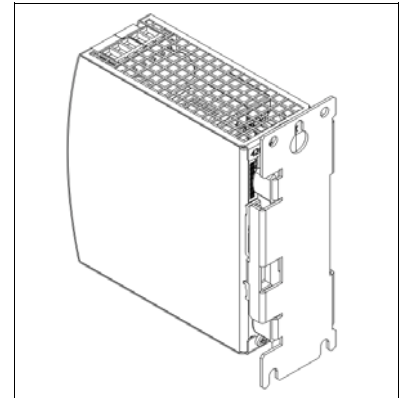

Fig. 23-4 **Wall/panel mounting, front view**
(Picture shows the CP20.241)

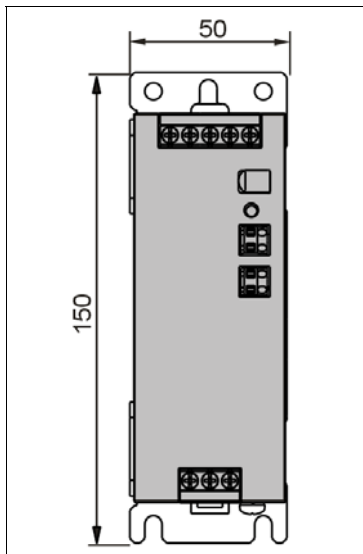

Fig. 23-5 **Hole pattern for wall mounting**

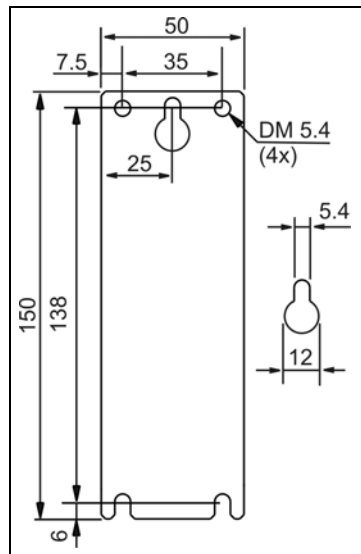
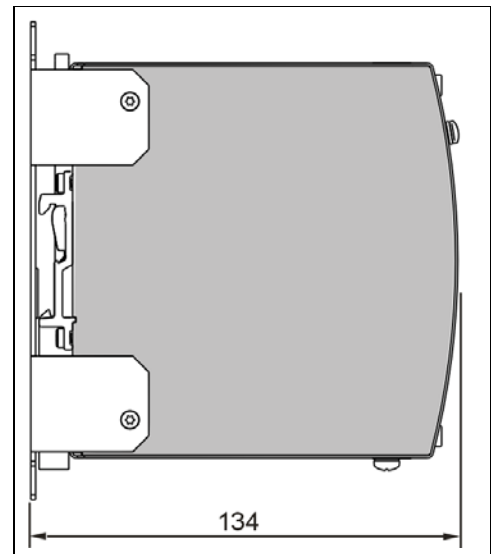

Fig. 23-6 **Wall/panel mounting, side view**
(Picture shows the CP20.241)



24. APPLICATION NOTES

24.1. PEAK CURRENT CAPABILITY

The unit can deliver peak currents (up to several milliseconds) which are higher than the specified short term currents. This helps to start current demanding loads. Solenoids, contactors and pneumatic modules often have a steady state coil and a pick-up coil. The inrush current demand of the pick-up coil is several times higher than the steady-state current and usually exceeds the nominal output current (including the PowerBoost). The same situation applies when starting a capacitive load.

The peak current capability also ensures the safe operation of subsequent circuit breakers of load circuits. The load branches are often individually protected with circuit breakers or fuses. In case of a short or an overload in one branch circuit, the fuse or circuit breaker need a certain amount of over-current to open in a timely manner. This avoids voltage loss in adjacent circuits.

The extra current (peak current) is supplied by the power converter and the built-in large sized output capacitors of the power supply. The capacitors get discharged during such an event, which causes a voltage dip on the output. The following examples show typical voltage dips:

Fig. 24-1 Peak load with 2x the nominal current for 50ms, typ.

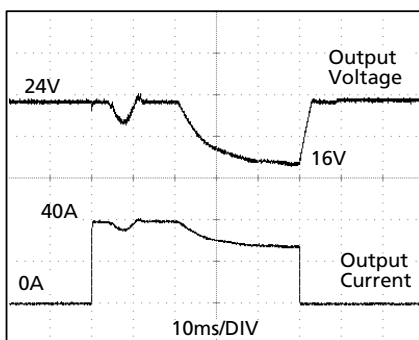

40A Peak load (resistive) for 50ms
Output voltage dips from 24V to 16V.

Fig. 24-2 Peak load with 5x the nominal current for 5ms, typ.

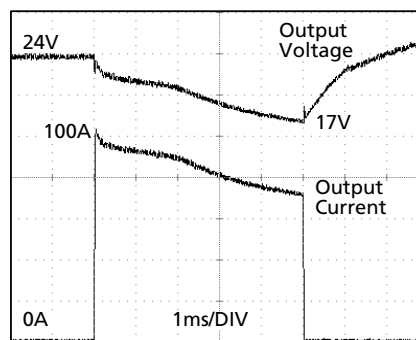

100A Peak load (resistive) for 5ms
Output voltage dips from 24V to 17V.

Fig. 24-3 60A Peak load for 12ms, typ.

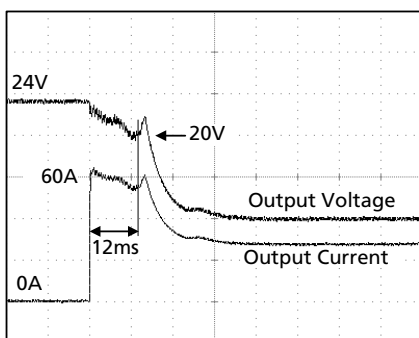

Please note: The DC-OK relay triggers when the voltage dips more than 10% for longer than 1ms.

Peak current voltage dips	typ.	from 24V to 16V	At 40A for 50ms, resistive load
	typ.	from 24V to 21V	At 100A for 2ms, resistive load
	typ.	from 24V to 17V	At 100A for 5ms, resistive load

May 2017 / Rev. 0.3 DS-CP20.241-EN
All parameters are typical values specified at 24V, 20A output, 230Vac input, 25°C ambient and after a 5 minutes run-in time unless otherwise noted.

24.2. BACK-FEEDING LOADS

Loads such as decelerating motors and inductors can feed voltage back to the power supply. This feature is also called return voltage immunity or resistance against Back- E.M.F. (Electro Magnetic Force).

This power supply is resistant and does not show malfunctioning when a load feeds back voltage to the power supply. It does not matter whether the power supply is on or off.

The maximum allowed feed-back-voltage is 35Vdc. The absorbing energy can be calculated according to the built-in large sized output capacitor which is specified in chapter 6.

24.3. EXTERNAL INPUT PROTECTION

The unit is tested and approved for branch circuits up to 30A (UL) and 32A (IEC). An external protection is only required if the supplying branch has an ampacity greater than this. Check also local codes and local requirements. In some countries local regulations might apply.

If an external fuse is necessary or utilized, minimum requirements need to be considered to avoid nuisance tripping of the circuit breaker. A minimum value of 10A B- or C-Characteristic breaker should be used.

24.4. OUTPUT CIRCUIT BREAKERS

Standard miniature circuit breakers (MCB's or UL 1077 circuit breakers) are commonly used for AC-supply systems and may also be used on 24V branches.

MCB's are designed to protect wires and circuits. If the ampere value and the characteristics of the MCB are adapted to the wire size that is used, the wiring is considered as thermally safe regardless of whether the MCB opens or not.

To avoid voltage dips and under-voltage situations in adjacent 24V branches which are supplied by the same source, a fast (magnetic) tripping of the MCB is desired. A quick shutdown within 10ms is necessary corresponding roughly to the ride-through time of PLC's. This requires power supplies with high current reserves and large output capacitors. Furthermore, the impedance of the faulty branch must be sufficiently small in order for the current to actually flow. The best current reserve in the power supply does not help if Ohm's law does not permit current flow. The following table has typical test results showing which B- and C-Characteristic MCBs magnetically trip depending on the wire cross section and wire length.

Fig. 24-4 Test circuit

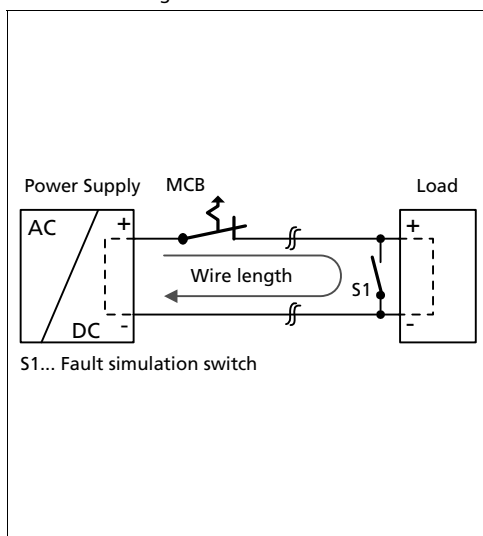

Maximal wire length^{*)} for a fast (magnetic) tripping:

	0.75mm²	1.0mm²	1.5mm²	2.5mm²
C-2A	31 m	37 m	63 m	98 m
C-3A	28 m	34 m	51 m	78 m
C-4A	18 m	25 m	38 m	58 m
C-6A	9 m	11 m	18 m	26 m
C-8A	6 m	7 m	12 m	14 m
C-10A	4 m	6 m	11 m	13 m
C-13A	2 m	2 m	4 m	7 m
<hr/>				
B-6A	23 m	28 m	46 m	66 m
B-10A	11 m	14 m	19 m	32 m
B-13A	7 m	11 m	16 m	29 m
B-16A	5 m	6 m	8 m	15 m
B-20A	1 m	1 m	2 m	4 m
B-25A				1 m

*) Don't forget to consider twice the distance to the load (or cable length) when calculating the total wire length (+ and - wire).

24.5. SERIES OPERATION

Power supplies of the same type can be connected in series for higher output voltages. It is possible to connect as many units in series as needed, providing the sum of the output voltage does not exceed 150Vdc. Voltages with a potential above 60Vdc are not SELV any more and can be dangerous. Such voltages must be installed with a protection against touching.

Avoid return voltage (e.g. from a decelerating motor or battery) which is applied to the output terminals.

Keep an installation clearance of 15mm (left / right) between two power supplies and avoid installing the power supplies on top of each other. Do not use power supplies in series in mounting orientations other than the standard mounting orientation (input terminals on bottom of the unit).

Pay attention that leakage current, EMI, inrush current, harmonics will increase when using multiple power supplies.

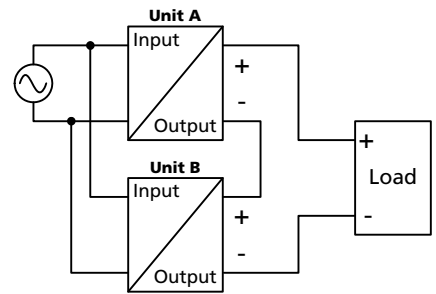

24.6. PARALLEL USE TO INCREASE OUTPUT POWER

CP20 power supplies can be paralleled to increase the output power. The output voltage of all power supplies shall be adjusted to the same value ($\pm 100\text{mV}$) in "Single use" mode with the same load conditions on all units, or the units can be left with the factory settings. After the adjustments, set the unit to "Parallel use" mode, in order to achieve load sharing. The "Parallel use" mode regulates the output voltage in such a manner that the voltage at no load is approx. 4% higher than at nominal load. See also chapter 6.

If more than three units are connected in parallel, a fuse or circuit breaker with a rating of 30A or 32A is required on each output. Alternatively, a diode or redundancy module can also be utilized.

Energize all units at the same time to avoid the overload Hiccup^{PLUS} mode. It also might be necessary to cycle the input power (turn-off for at least five seconds), if the output was in Hiccup^{PLUS} mode due to overload or short circuits and the required output current is higher than the current of one unit.

Keep an installation clearance of 15mm (left / right) between two power supplies and avoid installing the power supplies on top of each other. Do not use power supplies in parallel in mounting orientations other than the standard mounting orientation (input terminals on bottom of the unit) or in any other condition where a derating of the output current is required (e.g. altitude, above 60°C, ...).

Pay attention that leakage current, EMI, inrush current, harmonics will increase when using multiple power supplies.

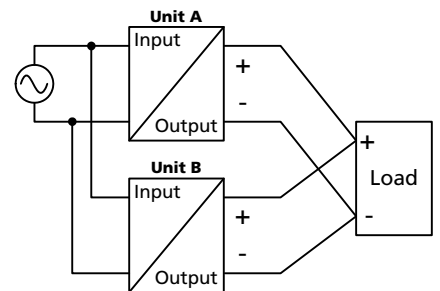

May 2017 / Rev. 0.3 DS-CP20.241-EN
All parameters are typical values specified at 24V, 20A output, 230Vac input, 25°C ambient and after a 5 minutes run-in time unless otherwise noted.

24.7. PARALLEL USE FOR REDUNDANCY

CP20 power supplies can be paralleled for redundancy to gain higher system availability. Redundant systems require a certain amount of extra power to support the load in case one power supply unit fails. The simplest way is to put two power supplies in parallel. This is called a 1+1 redundancy. In case one power supply unit fails, the other one is automatically able to support the load current without any interruption. Redundant systems for a higher power demand are usually built in a N+1 method. E.g. five power supplies, each rated for 20A are paralleled to build a 80A redundant system. For N+1 redundancy the same restrictions apply as for increasing the output power, see also chapter 24.6.

Please note: Always use a redundancy module to decouple power supplies from each other or use power supplies with built in redundancy like the CP20.241-R1 (spring-clamp terminals), the CP20.241-R2 (plug connectors for hot swap) or the CP20.241-R3 (screw terminals). This prevents that the defective unit becomes a load for the other power supplies and the output voltage cannot be maintained any more.

Recommendations for building redundant power systems:

- a) Use separate input fuses for each power supply.
- b) Set the power supply into "Parallel use" mode.
- c) Monitor the individual power supply units. Therefore, use the DC-OK relay contact of the CP20 power supply.
- d) It is desirable to set the output voltages of all units to the same value ($\pm 100\text{mV}$) or leave it at the factory setting.

Fig. 24-5 **1+1 Redundant configuration for 20A with one dual redundancy module**

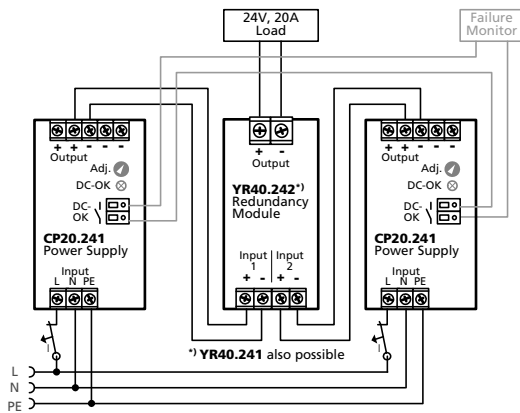
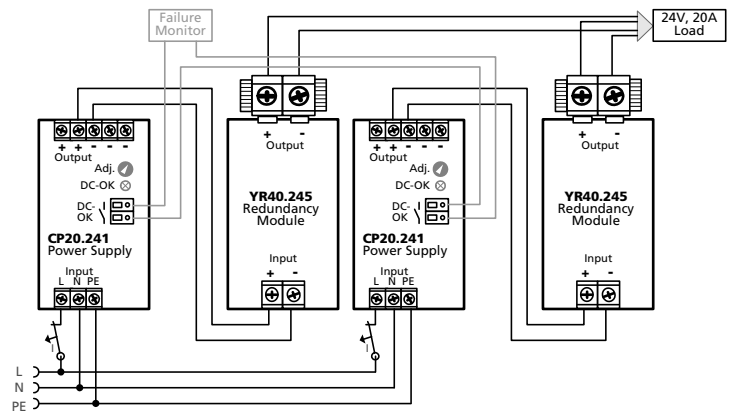

Fig. 24-6 **1+1 Redundant configuration for 20A with multiple YR40.245 redundancy modules**



24.8. INDUCTIVE AND CAPACITIVE LOADS

The unit is designed to supply any kind of loads, including capacitive and inductive loads. If extreme large capacitors, such as EDLCs (electric double layer capacitors or "UltraCaps") with a capacitance > 1F are connected to the output, the unit might charge the capacitor in the Hiccup^{PLUS®} mode (see chapter 6).

24.9. CHARGING OF BATTERIES

The power supply can be used to charge lead-acid or maintenance free batteries. Two 12V SLA or VRLA batteries are needed in series connection.

Instructions for charging batteries:

- a) Set output voltage (measured at no load and at the battery end of the cable) very precisely to the end-of-charge voltage.

End-of-charge voltage	27.8V	27.5V	27.15V	26.8V
Battery temperature	10°C	20°C	30°C	40°C

- b) Use a 30A or 32A circuit breaker (or blocking diode) between the power supply and the battery.
- c) Ensure that the output current of the power supply is below the allowed charging current of the battery.
- d) Ensure that the ambient temperature of the power supply stays below 40°C.
- e) Use only matched batteries when putting 12V types in series.
- f) The return current to the power supply (battery discharge current) is typ. 3.5mA when the power supply is switched off (except in case a blocking diode is utilized).

24.10. OPERATION ON TWO PHASES

The power supply can also be used on two-phases of a three-phase-system. Such a phase-to-phase connection is allowed as long as the supplying voltage is below 240V^{+10%}.

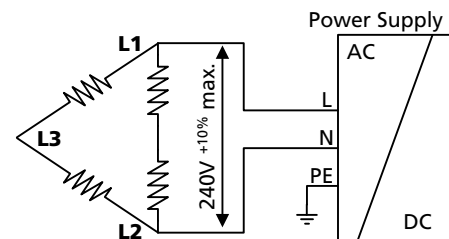

24.11. USE IN A TIGHTLY SEALED ENCLOSURE

When the power supply is installed in a tightly sealed enclosure, the temperature inside the enclosure will be higher than outside. In such situations, the inside temperature defines the ambient temperature for the power supply.

The following measurement results can be used as a reference to estimate the temperature rise inside the enclosure.

The power supply is placed in the middle of the box, no other heat producing items are inside the box

Enclosure:	Rittal Typ IP66 Box PK 9519 100, plastic, 180x180x165mm
Load:	24V, 16A; (=80%) load is placed outside the box
Input:	230Vac
Temperature inside enclosure:	51.7°C (in the middle of the right side of the power supply with a distance of 2cm)
Temperature outside enclosure:	25.9°C
Temperature rise:	25.8K

May 2017 / Rev. 0.3 DS-CP20.241-EN
 All parameters are typical values specified at 24V, 20A output, 230Vac input, 25°C ambient and after a 5 minutes run-in time unless otherwise noted.

24.12. MOUNTING ORIENTATIONS

Mounting orientations other than all terminals on the bottom require a reduction in continuous output power or a limitation in the maximum allowed ambient temperature. The amount of reduction influences the lifetime expectancy of the power supply. Therefore, two different derating curves for continuous operation can be found below:

Curve A1

Recommended output current.

Curve A2

Max allowed output current (results in approximately half the lifetime expectancy of A1).

Fig. 24-7
Mounting Orientation A
(Standard orientation)

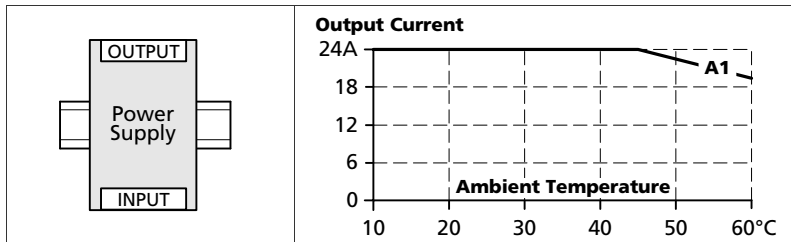

Fig. 24-8
Mounting Orientation B
(Upside down)

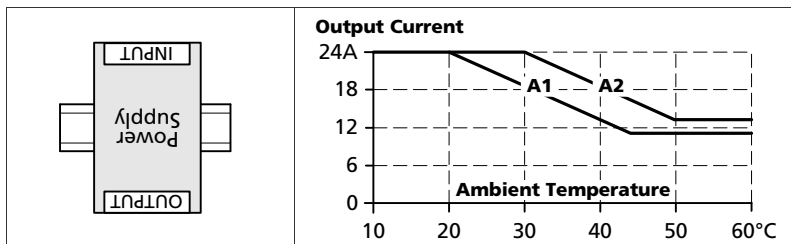

Fig. 24-9
Mounting Orientation C
(Table-top mounting)

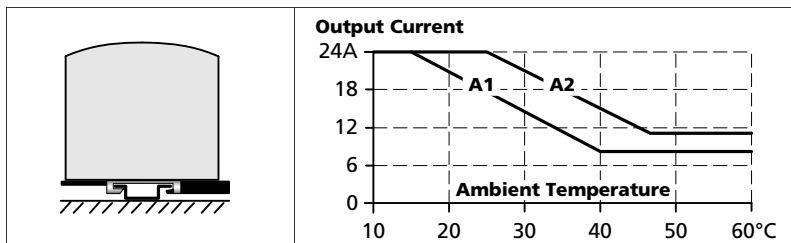

Fig. 24-10
Mounting Orientation D
(Horizontal cw)

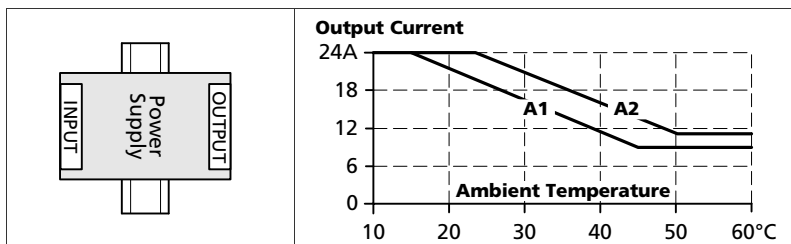
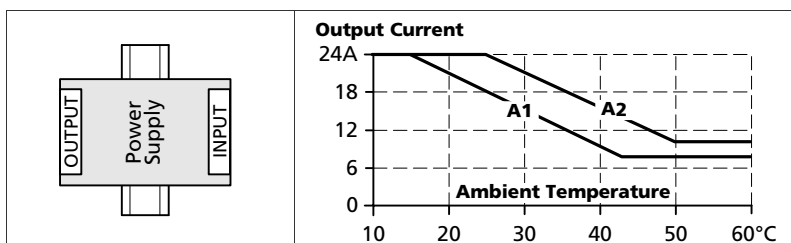

Fig. 24-11
Mounting Orientation E
(Horizontal ccw)



May 2017 / Rev. 0.3 DS-CP20.241-EN

All parameters are typical values specified at 24V, 20A output, 230Vac input, 25°C ambient and after a 5 minutes run-in time unless otherwise noted.